

Rack Mounting Instructions

This section provides information on installing the Arxys VideoX Professional Appliance into a rack unit. There are a variety of rack units on the market, which may mean the assembly procedures will differ slightly. You should also refer to the installation instructions that came with the rack unit you are using.

Installing the Inner Rails

1. Locate the inner rails.

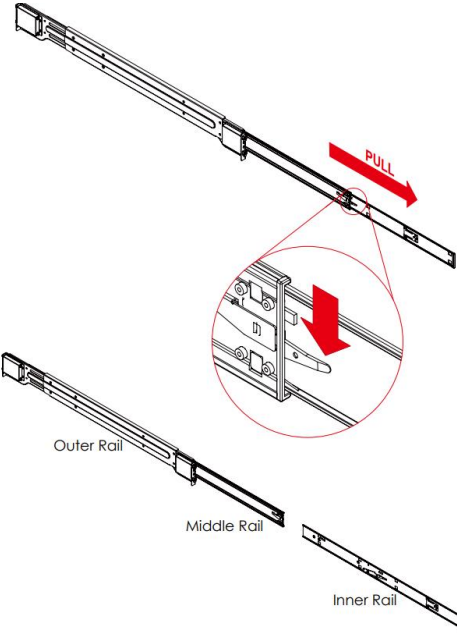

2. Pull the inner rail out of the outer rail until it is fully extended.
3. Press the locking tab down to release the inner rail.

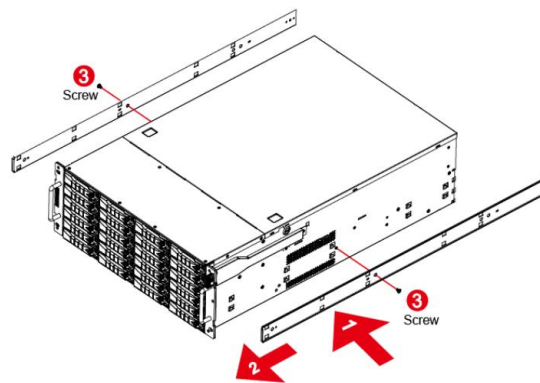

4. Place the inner rail firmly against the side of the chassis. Make sure that the hooks on the chassis are straight and aligned with the holes in the inner rail.

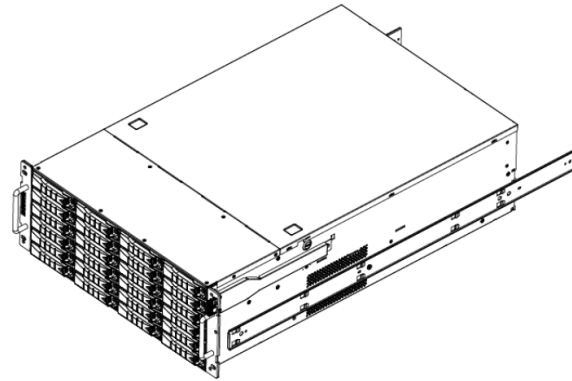

5. Slide the inner rail forward until it clicks into the locked position.

Installing the Outer Rails to the Rack

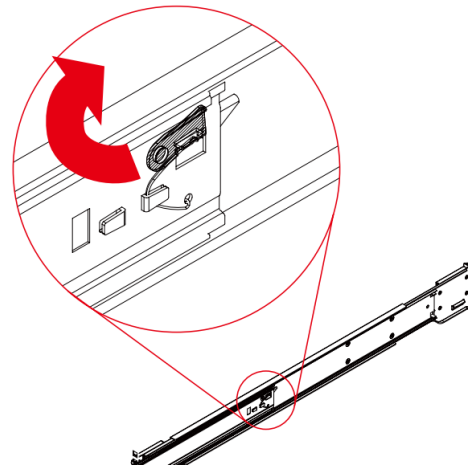

1. Press the locking tab and push the middle rail back into the outer rail.

Installing the Chassis to a Rack

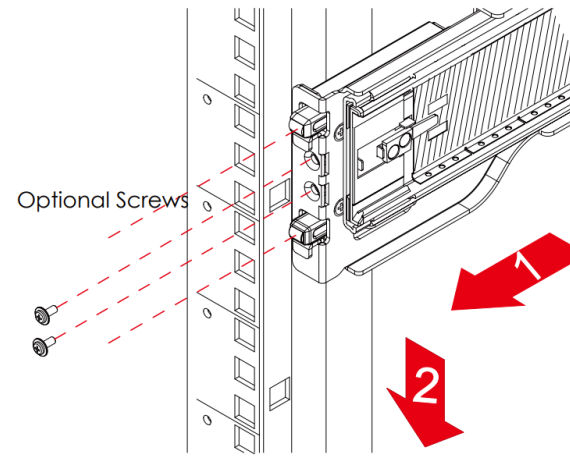

2. Align the rails with the square openings of the front of the rack.
3. Hang the rail hooks through and onto the corresponding openings in the rack
4. Secure with fasteners.

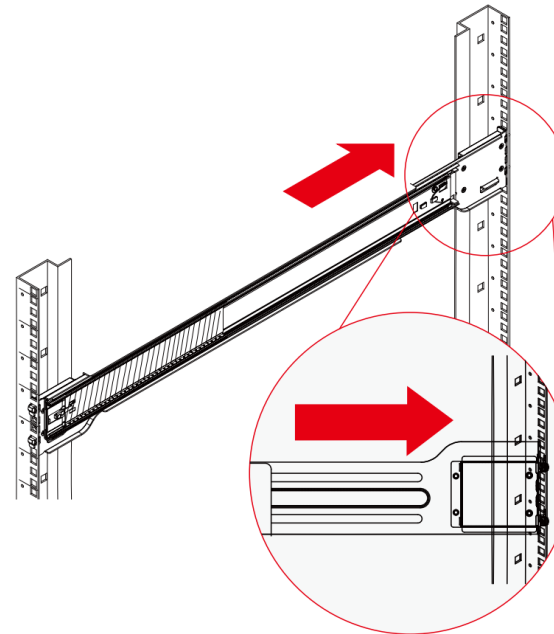

5. Hang the rail hooks through and onto the corresponding openings in the rear of the rack. Extend the rails as necessary.
6. Verify that the rail is level.

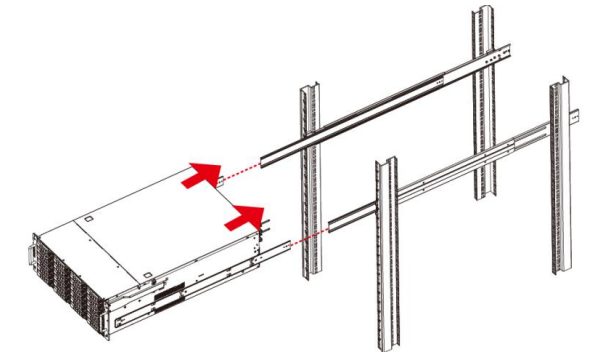

1. Pull the middle rail out of the outer rail.
2. Verify that the ball bearing shuttle is locked towards the front of the middle rail.
3. Align the inner rails mounted on the chassis with the middle rails and slide in the inner rails into the middle rails by pushing evenly on both sides until it clicks into the fully extended positions.

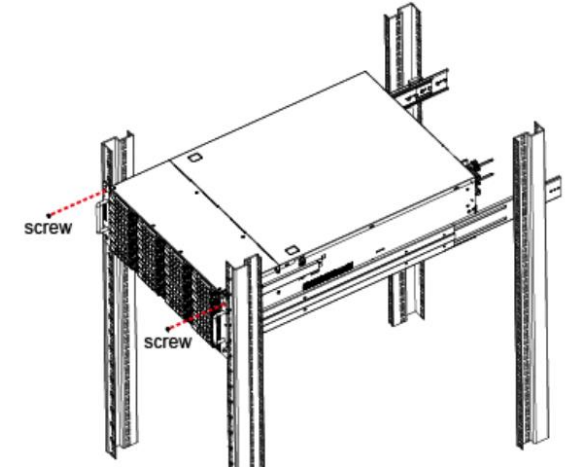

4. Press down on the locking tabs on both sides of the chassis and push the chassis again all the way back toward the rear of the rack.
5. Secure the chassis handles to the rack with fasteners.

Cabling Instructions

This section provides information on cabling the Arxys VideoX Professional Appliance before beginning operation.

Cabling the Arxys VideoX Professional Appliance

Connect cables to the Arxys VideoX Professional Appliance in the following order.

1. Connect a CAT 5/6 Ethernet cable to one or both Gigabit Ethernet ports (Ethernet cables are not provided).
2. Connect a monitor cable or KVM monitor adapter to the VGA port (monitor cable or KVM adapter is not provided).

Do **NOT** connect any display to the Display port or DVI port. Doing so will disable the IPMI remote KVM feature.

3. Connect a keyboard cable and mouse cable or KVM keyboard/mouse adapter to the USB ports (keyboard cable, mouse cable or KVM adapter is not provided).
4. Connect two power supply cables to the two power supplies. To ensure power redundancy use different power circuits.

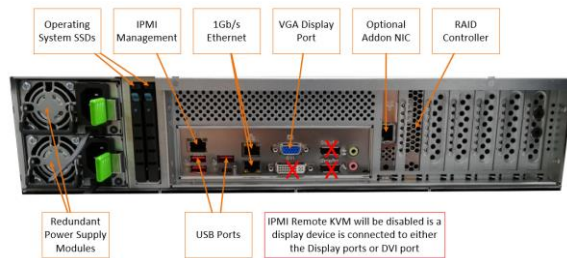

Drive Handling Instructions

This section provides information on the hard drives installed in the Arxys VideoX Professional Appliance and proper handling of those drives.

Arxys VideoX Professional Appliance Hard Drives

The hard drives are mounted in drive carriers to simplify their installation and removal from the Arxys VideoX Professional. These carriers also help promote proper airflow for the drive bays. For this reason, even empty carriers without drives installed must remain in the chassis.

IMPORTANT: Regardless of how many hard drives are installed, all drive carriers must remain in the drive bays to maintain proper airflow.

The boot drive(s) store the Windows operating system for the Arxys VideoX Professional. Additional disk drives to occupy any unoccupied drive slots may be purchased directly from Arxys. Installing non-Arxys drives in unoccupied drive slots will end the hardware warranty on the Arxys VideoX Professional.



Removing Hard Drive Carriers

1. Press the release button on the drive carrier. This extends the drive carrier handle.
2. Use the handle to pull the drive carrier out of the chassis.

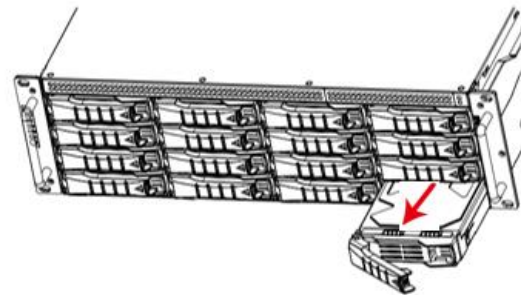

NOTE: Your Arxys VideoX Professional Appliance HDDs have RAID redundancy to ensure data availability in case of an HDD failure and support hot-plug capability of the hard drives. Replacement HDDs with carriers will ship directly from Arxys. Do not remove any hard drives while the unit is powered on without express instruction from a Technical Support Engineer.

Replacing Hard Drive Carriers

1. Replace the drive tray into the chassis. Make sure to press the drive carrier handle closed until it clicks in place.

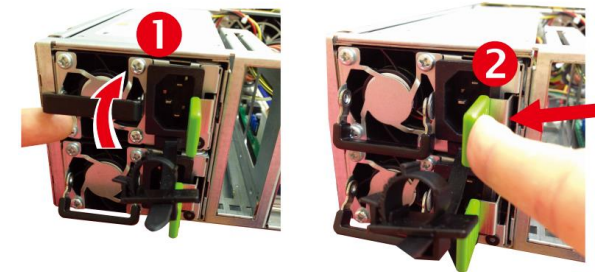
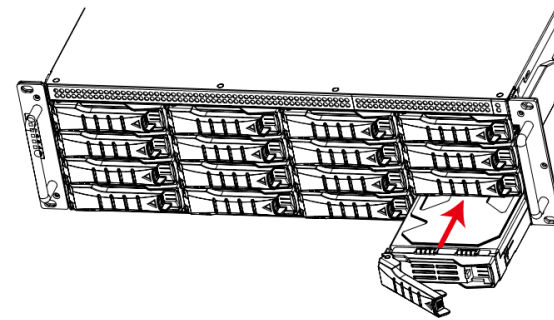

Installing a New Power Supply

1. Replace the failed hot-swap unit with another identical power supply unit.
2. Push the new power supply unit into the power bay until you hear a click.
3. Secure the locking tab on the unit.
4. Finish by plugging the AC power cord back into the unit.

Power Supply Instructions

This section provides information on the power supply installed in the Arxys VideoX Professional Appliance and proper handling of the power supply modules.

Power Supplies

The Arxys VideoX Professional Appliance has a high-efficiency redundant power supply consisting of two power modules. Each power supply module has an auto-switching capability, which enables it to automatically sense and operate at a 100V - 240V input voltage.



Power Supply Failure

If either of the two power supply modules were to fail, the other module will take the full load and allow the system to continue operation without interruption. The Power Failure LED on the control panel will flash and an audible alarm will sound until the failed unit has been replaced. Replacement power supply modules will ship directly from Arxys. The power supply units have a hot-swap capability, meaning you can replace the failed unit without powering down the system.

Removing the Power Supply

1. Unplug the AC power cord from the failed power supply module.
2. Wait a few seconds for the fan to spin down.
3. Press and hold the green release latch
4. Use the pull handle to gently pull the power supply module straight out and away from the system.

Technical Support

Submit a ticket by going to: <https://support.arxys.com>

