

## Rack Mounting Instructions

This section provides information on installing the Esri Data Appliance for ArcGIS chassis into a rack unit. There are a variety of rack units on the market, which may mean the assembly procedures will differ slightly. You should also refer to the installation instructions that came with the rack unit you are using.

**NOTE:** This rail will fit a rack between 26" and 33.5" deep. The inner rails come pre-installed on the Data Appliance for ArcGIS.

### Installing the Outer Rails to the Rack

1. Attach the longer section of the outer rail to the outside of the shorter section of the outer rail. You must align the pins with the slides. Both ends of the outer rail must face the same direction in order to be secured to the rack.
  2. Adjust both sections of the outer rail to the proper length so that the rail fits snugly within the rack.
  3. Secure the longer section of the outer rail to the front side of the rack with two M5 screws and the shorter section to the rear side of the rack with two M5 screws.
- Repeat steps 2-3 for the remaining outer rail.

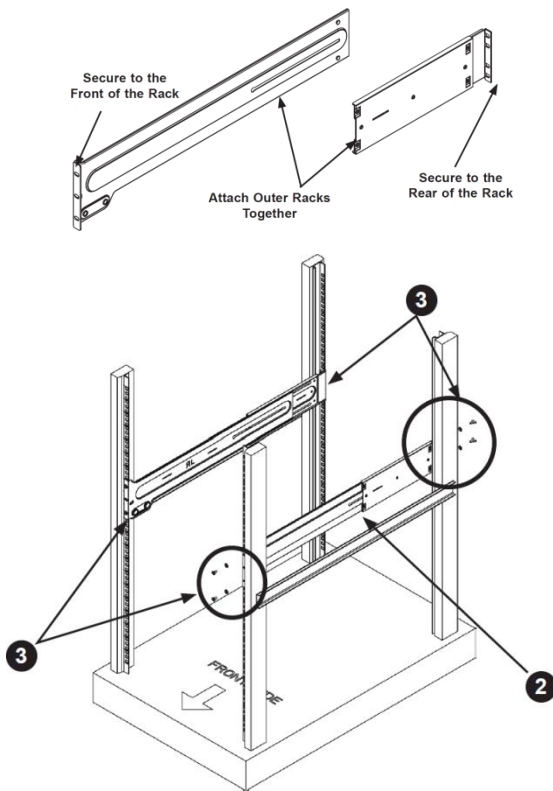

### Installing the Chassis to a Rack

1. Confirm that chassis includes the inner rails (A) and rail extensions (B). Also, confirm that the outer rails (C) are installed on the rack.
  2. Line chassis rails (A and B) with the front of the rack rails (C).
  3. Slide the chassis rails into the rack rails, keeping the pressure even on both sides (you may have to depress the locking tabs when inserting). When the server has been pushed completely into the rack, you should hear the locking tabs "click" into the locked position.
- (Optional) Insert and tighten the thumbscrews that hold the front of the server to the rack.

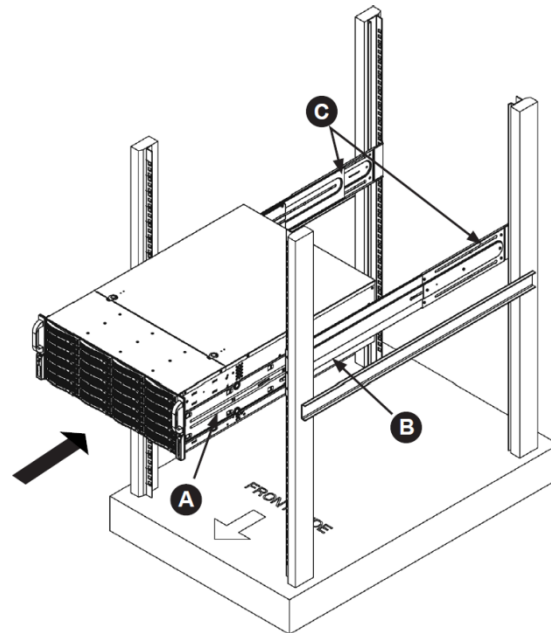

### Rail Screws

The accessory box includes all the screws needed to install the chassis in a rack. This section lists and describes the most common screws used. The chassis may not require all the parts listed.

| Item | Qty | Description                       |
|------|-----|-----------------------------------|
| 1    | 4   | M4 x 4mm (0.157) Flat Head Screw  |
| 2    | 22  | M4 x 4mm (0.157) Round Head Screw |
| 3    | 8   | M5 x 12mm (0.472) Flat Head Screw |
| 4    | 8   | Washer for M5 Flat Head Screw     |



## Cabling Instructions

This section provides information on cabling the Data Appliance for ArcGIS before beginning operation.

### Cabling the Data Appliance for ArcGIS

Connect cables to the Data Appliance for ArcGIS in the following order.

1. Connect a CAT 6 Ethernet cable to one or both Gigabit Ethernet ports (Ethernet cables are not provided).
2. Connect a monitor cable or KVM monitor adapter to the VGA port (monitor cable or KVM adapter is not provided).
3. Connect a PS2 keyboard cable and mouse cable or KVM keyboard/mouse adapter to the keyboard and mouse ports (keyboard cable, mouse cable or KVM adapter is not provided).
4. Connect two power supply cables to the two power supplies. To ensure power redundancy use different power circuits. Power supply cables are provided with the Data Appliance for ArcGIS.
5. Connect a CAT6 Ethernet cable to the IPMI port (Ethernet cable is not provided.)

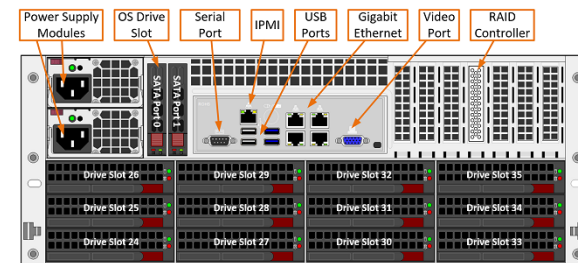

## Drive Handling Instructions

This section provides information on the hard drives installed in the Data Appliance for ArcGIS and proper handling of those drives.

### Data Appliance for ArcGIS Hard Drives

The hard disk drives (Drive 0 – Drive 23), or HDDs, of the Data Appliance for ArcGIS store the Esri data collections purchased from, and licensed by Esri. The hard drives are mounted in drive carriers to simplify their installation and removal from the Data Appliance for ArcGIS. These carriers also help promote proper airflow for the drive bays. For this reason, even empty carriers without drives installed must remain in the chassis.

**IMPORTANT:** Regardless of how many hard drives are installed, all drive carriers must remain in the drive bays to maintain proper airflow.

An internal boot drive (not shown) stores the Windows Storage Server operating system for the Data Appliance for ArcGIS. Additional disk drives to occupy any unoccupied drive slots may be purchased from Esri and will ship directly from Arxys.

Installing non-Arxys drives in unoccupied drive slots will end the hardware warranty on the Data Appliance for ArcGIS.

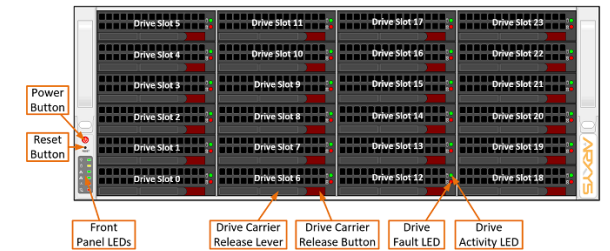

### Removing Hard Drive Carriers

1. Press the release button on the drive carrier. This extends the drive carrier handle.
2. Use the handle to pull the drive carrier out of the chassis.

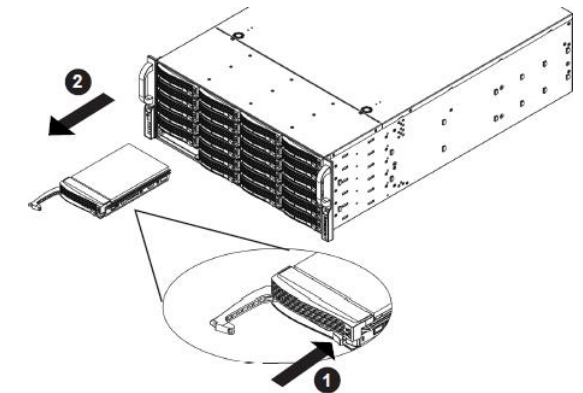

**NOTE:** Your Data Appliance for ArcGIS HDDs have RAID redundancy to ensure data availability in case of an HDD failure and support hot-plug capability of the hard drives. Replacement HDDs with carriers will ship directly from Arxys. Do not remove any hard drives while the unit is powered on without express instruction from a Technical Support Engineer.

### Replacing Hard Drive Carriers

1. Replace the drive tray into the chassis. Make sure to press the drive carrier handle closed until it clicks in place.

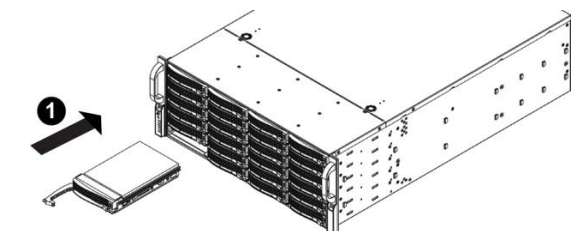

## Power Supply Instructions

This section provides information on the power supply installed in the Data Appliance for ArcGIS and proper handling of the power supply modules.

### Power Supplies

The Data Appliance for ArcGIS has a 1200 watt high-efficiency 80 PLUS Titanium Certified (96%) redundant power supply consisting of two power modules. Each power supply module has an auto-switching capability, which enables it to automatically sense and operate at a 100V - 240V input voltage.



### Power Supply Failure

If either of the two power supply modules were to fail, the other module will take the full load and allow the system to continue operation without interruption. The Power Failure LED on the control panel will flash and an audible alarm will sound until the failed unit has been replaced. Replacement power supply modules will ship directly from Arxys. The power supply units have a hot-swap capability, meaning you can replace the failed unit without powering down the system.

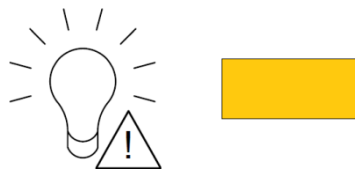

### Removing the Power Supply

Unplug the AC power cord from the failed power supply module.

1. Depress the release tab on the power supply module.
2. Use the handle to pull it straight out with the rounded handle.

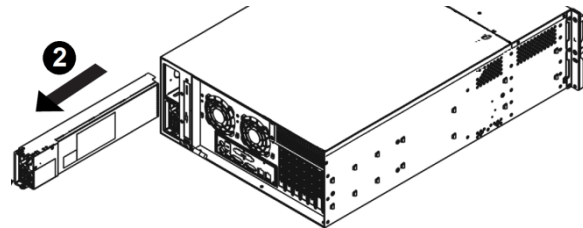
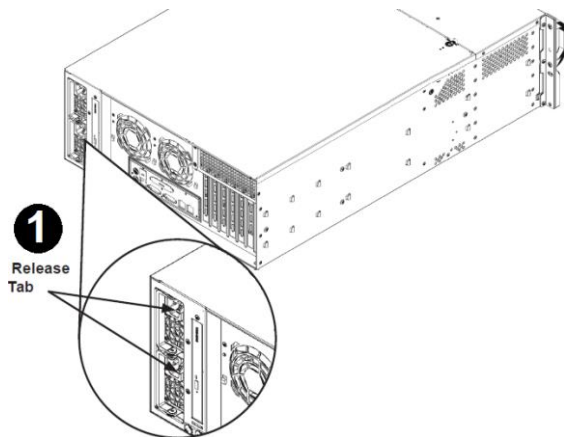

### Installing a New Power Supply

1. Replace the failed hot-swap unit with another identical power supply unit.
  2. Push the new power supply unit into the power bay until you hear a click.
  3. Secure the locking tab on the unit.
- Finish by plugging the AC power cord back into the unit.

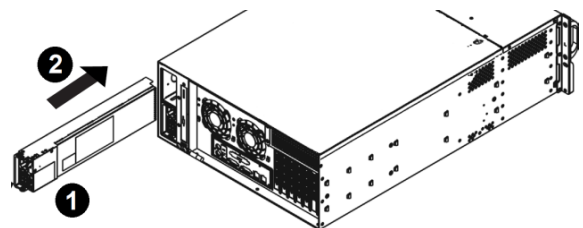

## System Interface

This section provides information on the buttons and LED indicators located on the front of the Data Appliance for ArcGIS chassis, their use and appropriate responses required.

### Data Appliance for ArcGIS Control Panel

There are several buttons and LEDs on the control panel of the Data Appliance for ArcGIS that provide system and component status.

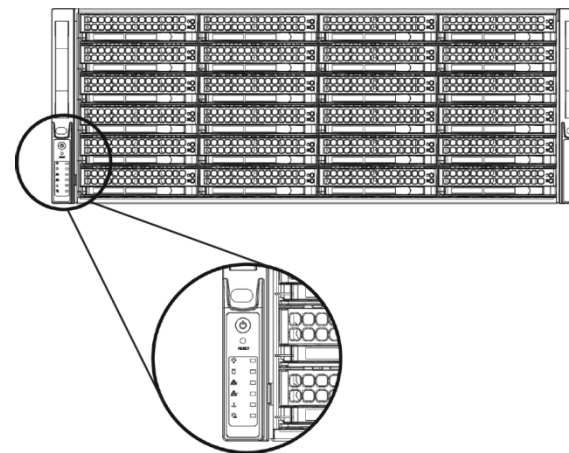

### Control Panel Buttons

The Data Appliance for ArcGIS includes two push buttons located on the control panel.



**Power:** The main power switch is used to apply or remove power from the power supply to the Data Appliance for ArcGIS.



RESET

**Reset:** The reset button is used to manually reboot the Data Appliance for ArcGIS.

### Control Panel LEDs

The Data Appliance for ArcGIS control panel has five LEDs. These LEDs provide critical information related to different parts of the storage system. This section explains what each LED indicates when illuminated and any action that may be required.



**Overheat/Fan Fail:** When this LED flashes, it indicates a fan failure. When continuously on (not flashing) it indicates an overheat condition, which may be caused by the ambient room temperature being too warm. This LED will remain flashing or on as long as the overheat condition exists.



**NIC2:** Indicates network activity on Gigabit Ethernet LAN2 when flashing.



**NIC1:** Indicates network activity on Gigabit Ethernet LAN1 when flashing.



**HDD:** Indicates SAS/SATA drive and/or DVD-ROM drive activity when flashing.



**Power:** Indicates power is being supplied to the system's power supply units. This LED should normally be illuminated when the system is operating.



**Power Failure:** When this LED flashes, it indicates a failure in the power supply.

### Drive Carrier LEDs

The Data Appliance for ArcGIS uses SATA hard disk drives mounted in drive carriers. Each SATA drive carrier has two LEDs.

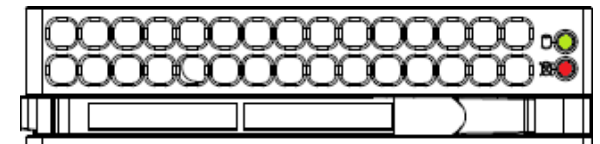

**Upper Green LED:** When illuminated, this green LED indicates drive activity.

**Lower Red LED:** The red LED indicates a SATA drive failure.

### Power Supply LEDs

The Data Appliance for ArcGIS includes two power supply modules. Each power supply module has a dual color LED.

| State       | Indication                           |
|-------------|--------------------------------------|
| Solid Green | System is powered on                 |
| Solid Amber | System is plugged in but powered off |
| LED Off     | Power supply module not plugged in   |

